

Travaux Dirigés 2 - Correction

Les chaines structurelles

Exercice 1 : Echelle pivotante

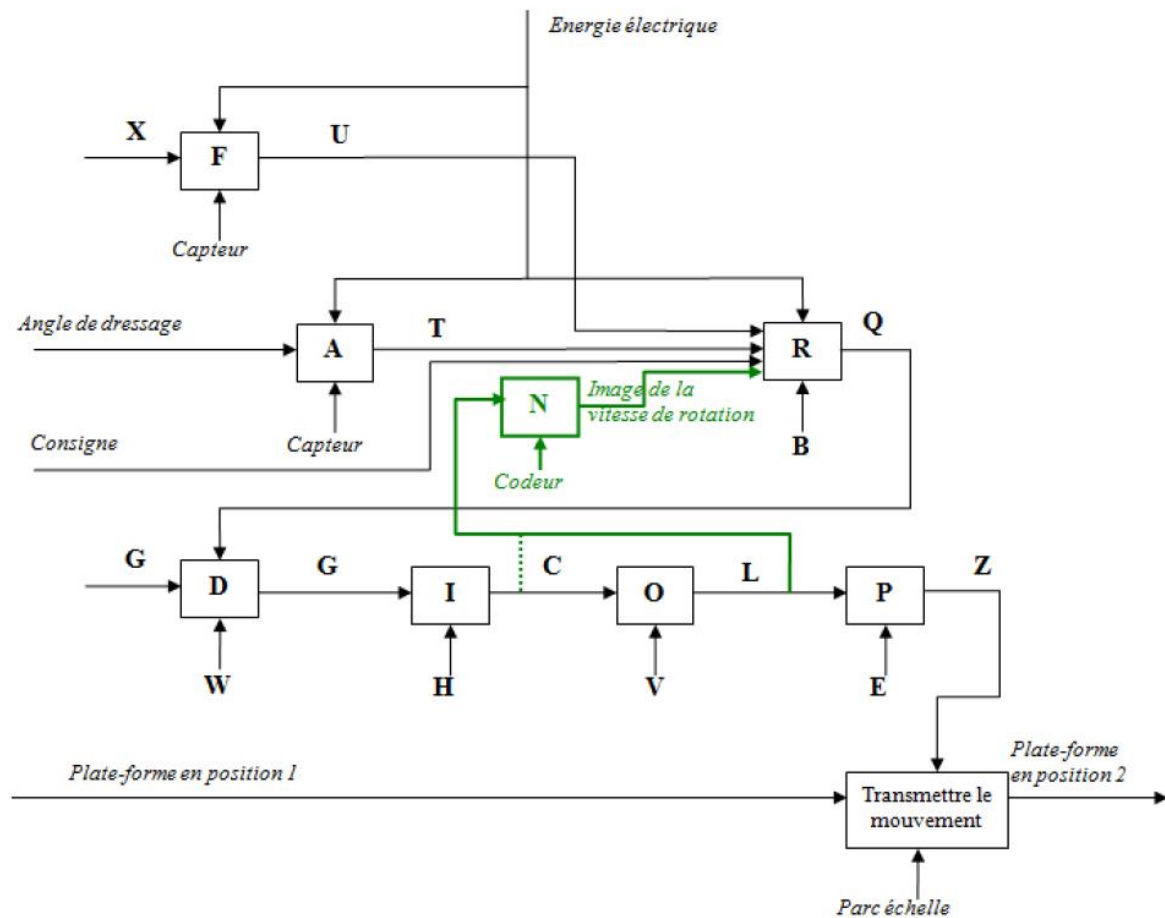

Exercice 2 : prothèse active

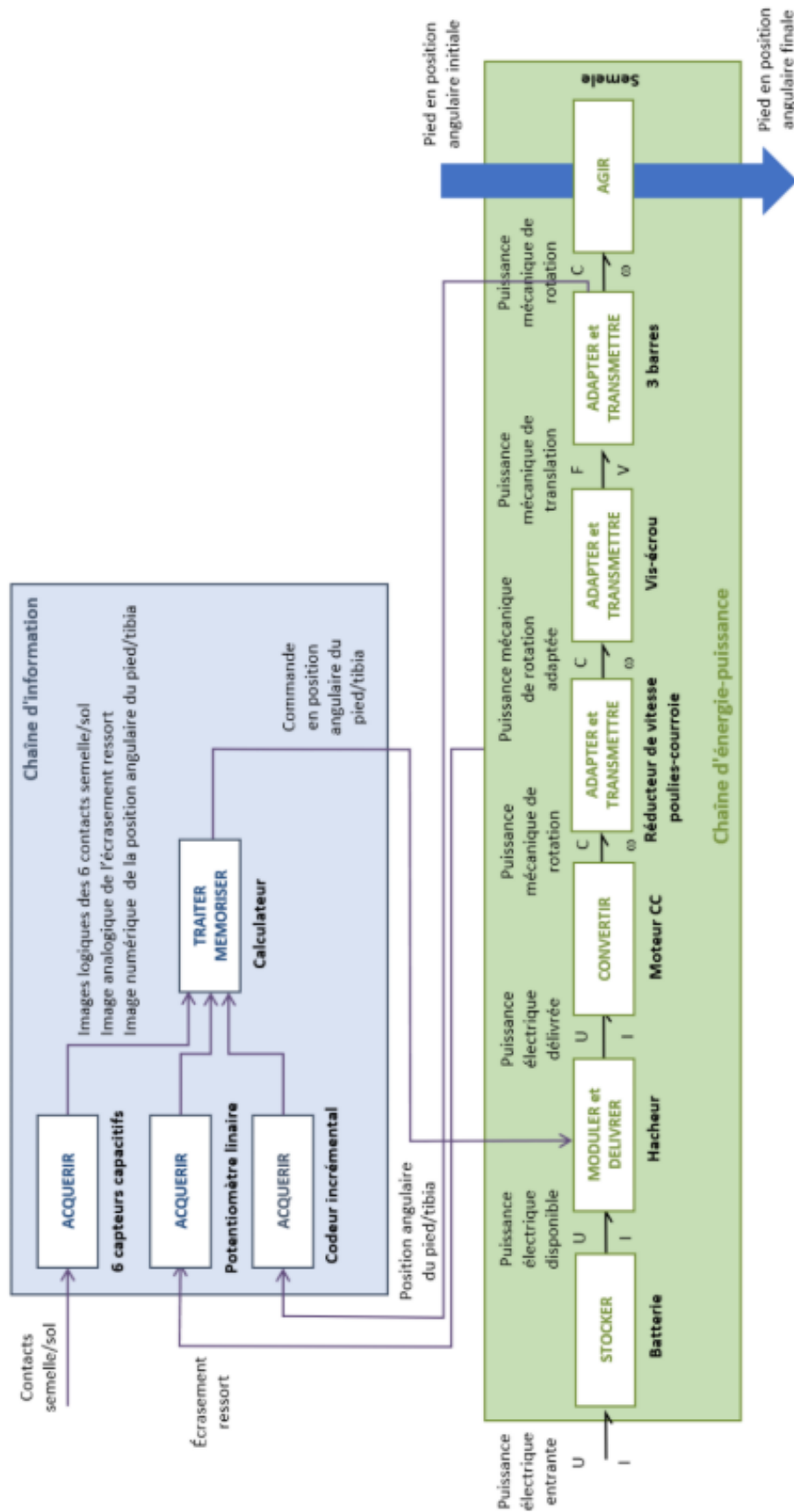

Exercice 3 : sècheuse électrique

